



EP 250 PUMP

Applications:

- Cutting, turning, milling, boring, grinding and similar applications of the machine tools,
- Filtration systems,
- Circulation systems. EP Pumps are used for pumping of cutting / cooling fluids.

Fluid Specifications:

- Coolants,
- Cutting oils,
- Grinding oils,
- Water,
- Chip contains liquids (max. 8mm)
- Fluid temperature 0...60 °C
- Kinematic viscosity 1...90 mm²/s

Materials:

Pump body	: Cast iron - DIN GG 25
Volute	: Cast iron - DIN GG 25
Impeller	: Investment casting steel - AISI 4140 (DIN 42CrMo4)
Pump shaft	: Engineering steel - AISI 1040 (DIN C35)
Electric motor	: 3 phase induction motor 2 pole, 3000 rpm Protection degree IP 55

DIMENSIONS & NOMINAL VALUES

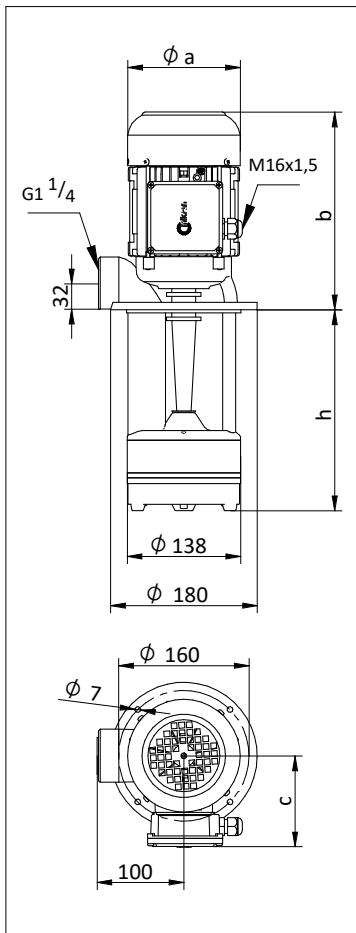

TYPE	Depth of immersion h (mm)	a	b	c	Weight kg	Power kW	Voltage V(Δ/Y)	Frequency Hz	Rated current A	Speed rpm
		mm								
EP 250/200	200	138	242	111	14.5	0.55	230/400	50	2.25/1.3	2780
EP 250/270	270				15.0					
EP 250/350	350				15.5					
EP 250/440	440				17.0					
EP 250/550	550				18.5					
EP 252/250	250	138	242	111	20.5	1.1	230/400	50	4.85/2.8	2780
EP 252/320	320				21.0					
EP 252/400	400				22.0					
EP 252/490	490				23.5					
EP 253/300	300	176	309	139	27.0	1.5	230/400	50	5.72/3.3	2910
EP 253/370	370				27.5					
EP 253/450	450				28.0					

* Pump dimensions according to EN 12157.

** The performance curves are based on 1 mm²/s (cSt) kinematic viscosity values and 1000 kg/m³ density

*** Curve tolerance according to EN ISO 9906.

**** EP 252 pump has IE2 motor. According to IEC 60034-30-1:2014 standard this pump is excluded from efficiency class since its motor is completely integrated into the pump.

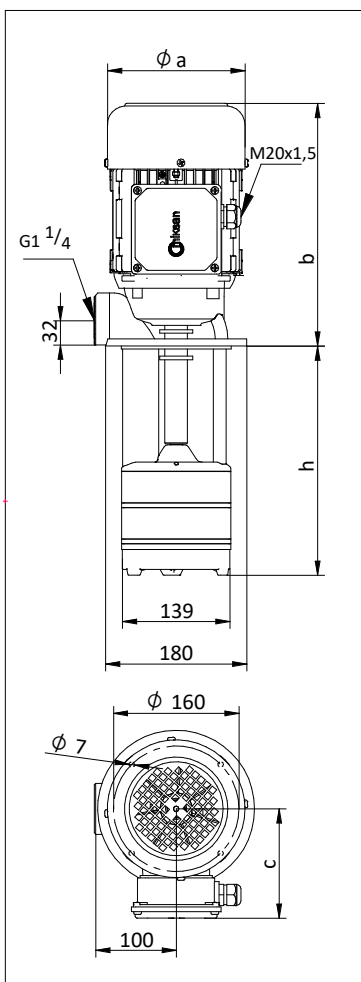

Performance Curve

